

GALAXIA



ASTRO

4 ASTRO CARBON

6 ASTRO STARWHITE

8 ASTRO TITANIUM

DUAL

14 DUAL-T CARBON / STARWHITE

16 DUAL-V CARBON / STARWHITE

QUATTRO

18 CARBON / STARWHITE

22 **BALLAST**

23 **ACCESSORIES**

24 **FABRIC COLLECTION**

28 **KIT LED GALAXIA**

30 **MATERIALI E FINITURE / MATERIALS AND FINISHING**



I

Abbiamo ideato un nuovo futuro per vivere lo spazio esterno dominato da sinergia tra:

- Tecnologia
- Ergonomia
- Design
- Innovazione

La sapienza e l'eccellenza italiana artigiana si sono evolute e raffinate attraverso studi accurati e dedicati, tecnologici e di ingegneria, ottenendo risultati STRATOSFERICI: GALAXIA.

EN

We have created a futuristic way of living the outdoors through the synergic combination of:

- Technology
- Ergonomics
- Design
- Innovation

Italian wisdom and artisanal excellence have evolved and been refined through dedicated technological and engineering studies, producing stratospheric results: GALAXIA.

D

Futuristisch innovative Art im Freien zu leben Synergie zwischen:

- Technologie
- Ergonomie
- Design
- Innovation

Die Weisheit und die handwerkliche italienische Exzellenz haben sich weiterentwickelt und verfeinert durch genaue, relevante, technologische und technische Forschungen. Es wurden stratosphärische Ergebnisse erzielt: GALAXIA.

F

Nous avons créé un nouveau produit reposant sur un nouveau concept , la synergie entre :

- Technologie
- Ergonomie
- Conception
- Innovation

L'excellence et le raffinement de l'artisanat italien ont évolué grâce à des études précises et des avancées technologiques de l'ingénierie , permettant d'obtenir des résultats exceptionnels: GALAXIA.

E

Hemos ideado un nuevo futuro para vivir el espacio exterior en sinergia dominado entre:

- Tecnología
- Ergonomía
- Diseño
- Innovación

La sabiduría y la excelencia italiana artesana se han evolucionado y perfeccionado a través de estudios cuidadosos y dedicados, tecnológicos y de ingeniería, obteniendo resultados ESTRATOSFÉRICOS: GALAXIA.

MOTION

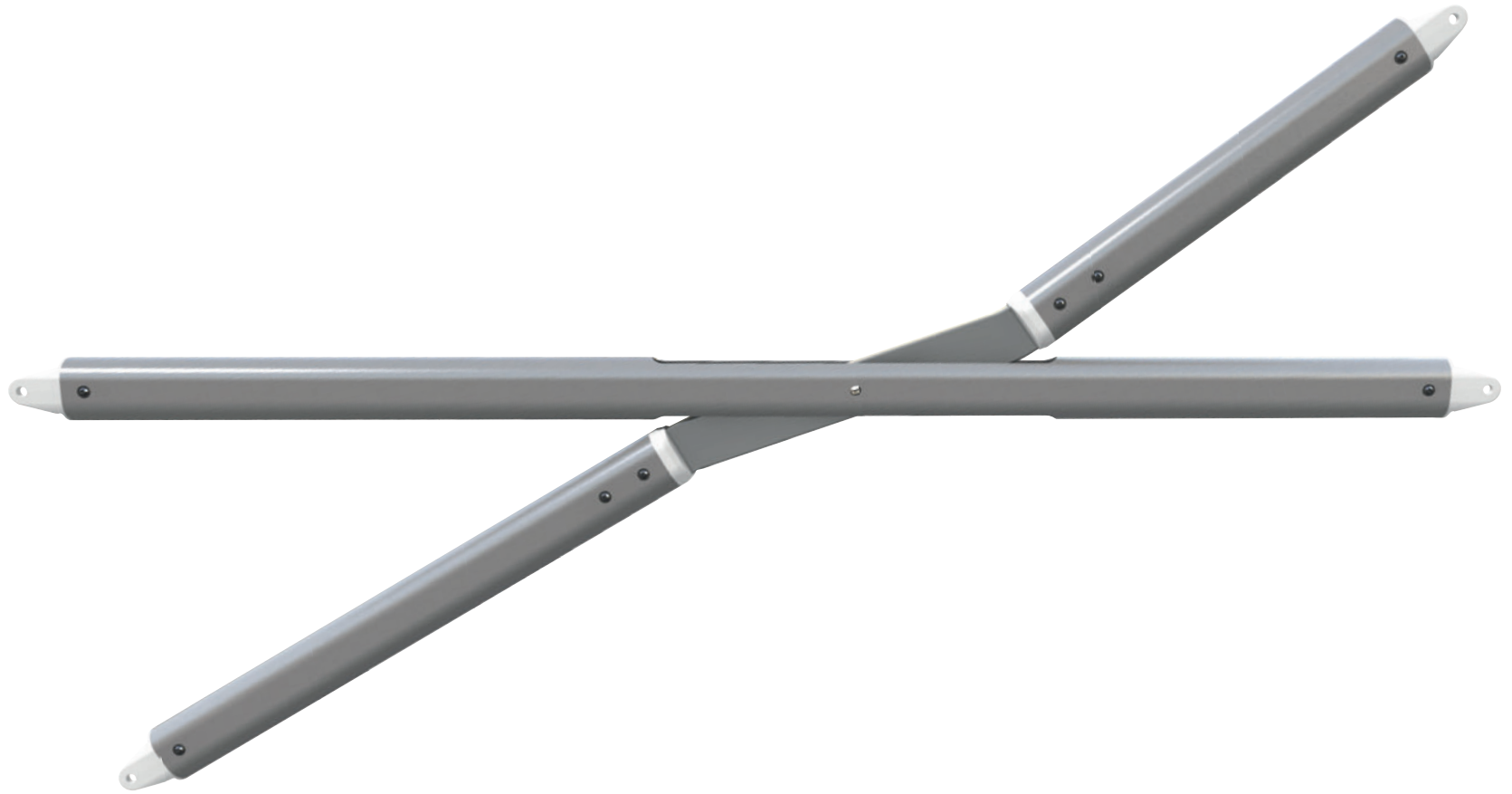

I

SISTEMA "MOTION"
Alla base del funzionamento innovativo c'è il Sistema Motion, che evolve il concetto di apertura e chiusura retrattile dell'ombrellone. In questa applicazione innovativa i bracci a forbice azionano direttamente le corone centrali per l'apertura e la chiusura.

EN

SYSTEM "MOTION"
The revolutionary MOTION system allows the umbrella to open and retract in one motion. The innovative scissor arms activate the central crowns which in turn open and close the umbrella.

D

SYSTEM "MOTION"
An der Basis des innovativen Betriebs befindet sich das System Motion, dass das Konzept der Öffnung und Schließung des einziehbaren Schirmes entwickelt. In dieser innovativen Anwendung setzen die scherenförmige Arme direkt die zentralen Kronen zum Öffnen und Schließen in Bewegung.

F

SYSTEM "MOTION"
A la base de l'opération novatrice il y a le système Motion, qui évolue le concept d'ouverture et de fermeture du parasol rétractable. Dans cette innovante les bras à ciseaux operant directement sur les couronnes centrales pour l'ouverture et la fermeture.

E

SISTEMA "MOTION"
A la base de la operación innovadora está el sistema de movimiento, que evoluciona el concepto de abrir y cerrar el parasol retráctil. En esta aplicación innovadora, los brazos de tijeras conducen directamente las coronas centrales por apertura y cierre.

LIFT ACTION



ERGONOMY DESIGN



I

LIFT ACTION

La principale innovazione è l'applicazione di una molla a gas che agisce sul sistema MOTION assistendo l'apertura e riducendo al minimo lo sforzo in fase di apertura e chiusura dell'ombrellone.

ERGONOMY DESIGN

Non solo tecnologia e funzionalità, ma anche ergonomia nei movimenti. Il design e il gusto italiano incidono sapientemente e rendono ogni singola linea trasmettendo sensazioni di equilibrio nelle forme.

EN

LIFT ACTION

The main innovation is in the hydraulic gas strut which activates the MOTION system, assisting the mechanical operation and minimizing the effort required to open and close the umbrella.

ERGONOMIC DESIGN

Technology, functionality and ergonomic movements. Italian design and style make this umbrella unique, giving a sense of balance to its modern shape.

D

LIFT ACTION

Die wichtigste Neuerung ist die Anwendung einer Gasdruckfeder, die auf das System Motion wirkt und eine mühelose Öffnung und Schließung des Schirmes ermöglicht.

ERGONOMY DESIGN

Nicht nur Technik und Funktionalität, sondern auch Ergonomie der Bewegung. Das Design und das italienische Design haben einen grossen Einfluss und machen aus diesem Schirm ein einzigartiges Produkt. Jede einzelne Linie uebermittelt Gleichgewicht.

F

LIFT ACTION

La principale innovation est la présence d'un ressort à gaz agissant sur le fonctionnement du parasol en facilitant l'ouverture et en réduisant l'effort d'ouverture et de fermeture du parasol.

ERGONOMY DESIGN

Non seulement la technologie et la fonctionnalité, mais aussi l'ergonomie du mouvement. La conception et l'influence de style italien à bon escient et de faire ce parasol unique dans chaque ligne, transmettant des sentiments d'équilibre dans les formes.

E

LIFT ACTION

La principal innovación es la aplicación de un muelle de gas que actúa sobre el sistema de movimiento por ayudar a la apertura y reducir al mínimo el esfuerzo en la apertura y cierre del parasol.

ERGONOMY DESIGN

No sólo la tecnología y funcionalidad, sino también ergonomía de movimiento. El diseño y la influencia de estilo italiano inciden sabiamente y hacen este parasol único en cada línea, transmitiendo la sensación de equilibrio en las formas.





Astro Carbon



I
Connubio tra il futuro e il classico. Armonico per tutti gli ambienti. Telaio con effetto graffite metallizzato, unico nel suo genere.

EN
Marriage between the future and the classic. Harmonious for all environments. Frame with unique metallic graphite effect.

D
Verbindung zwischen Zukunft und Klassiker. Harmonisch für alle Bereiche. Gestell mit einzigartigem Metallic-Graphit Effekt.

F
Mariage entre l'avenir et le classique. Harmonieux pour tous les environnements. Armature avec effet métallique de graphite, produit unique.

E
Connubio entre el futuro y el clásico. Armonioso para todos los ambientes. Marco con efecto de grafito metálico, único en su género.

	
300x300	300x400
350x350	







Astro StarWhite

I
Prodotto futuristico, adatto per ambienti moderni e minimalisti.
Telaio con finitura effetto StarWhite.

EN
Futuristic product suitable for modern and minimalist settings.
The frame has a StarWhite powder-coated finish.

D
Futuristisches Produkt, geeignet für moderne und minimalistische Bereiche.
Gestell mit StarWhite Effekt.

F
Produit futuriste, adapté aux environnements modernes et minimalistes. Finition structure d'effet StarWhite.

E
Producto futurista, adecuado para ambientes modernos y minimalistas.
Estructura acabada efecto StarWhite.

300x300	300x400
350x350	





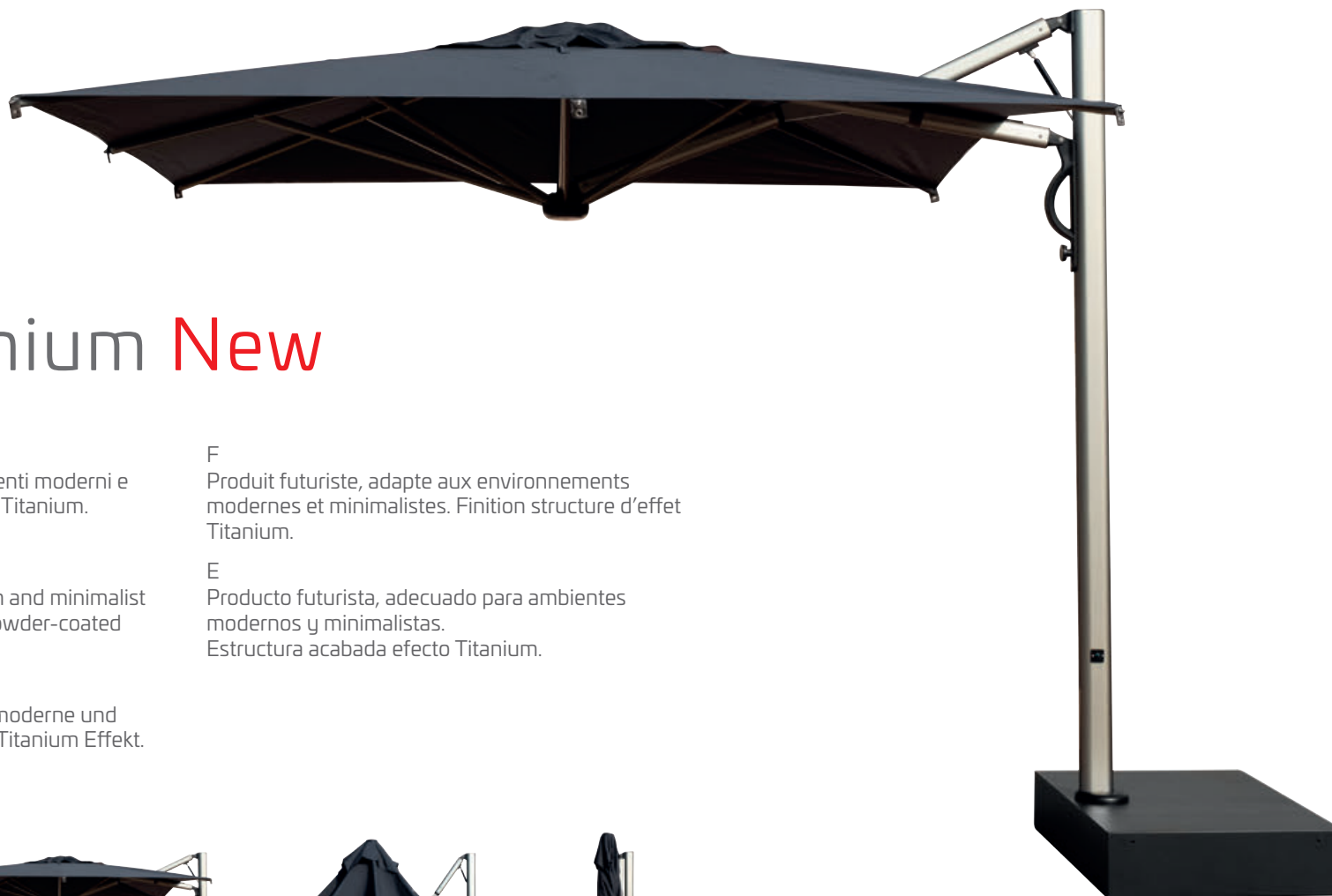

Astro Titanium **New**

I
Prodotto futuristico, adatto per ambienti moderni e minimalisti. Telaio con finitura effetto Titanium.

EN
Futuristic product suitable for modern and minimalist settings. The frame has a Titanium powder-coated finish.

D
Futuristisches Produkt, geeignet für moderne und minimalistische Bereiche. Gestell mit Titanium Effekt.

F
Produit futuriste, adapte aux environnements modernes et minimalistes. Finition structure d'effet Titanium.

E
Producto futurista, adecuado para ambientes modernos y minimalistas. Estructura acabada efecto Titanium.

300x300	300x400
350x350	



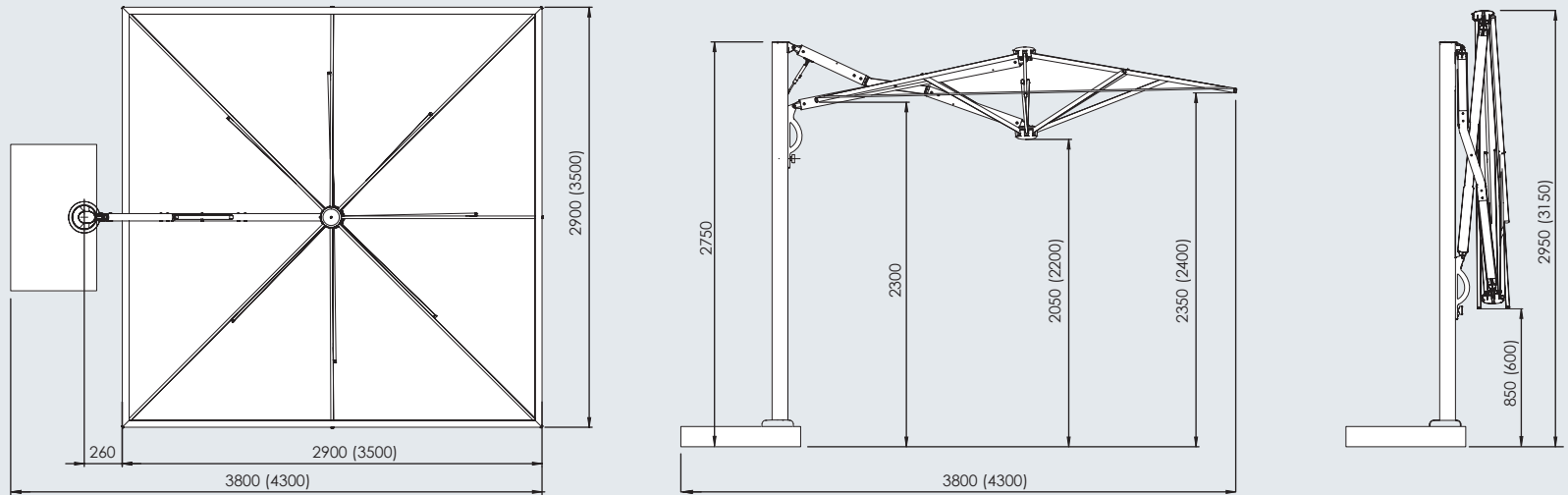

Astro

StarWhite
Carbon
Titanium

CHARACTERISTICS										FINISHING					
	COD	KG													INOX
3,0x3,0	STARWHITE C3030 ASW	55	0,45	110x76	STAR WHITE	8	STAR WHITE	18x30	●	●	●	●	●	●	●
	CARBON C3030 ASC				CARBON		CARBON								
	TITANIUM C3030 AST				TITANIUM		TITANIUM								
3,5x3,5	STARWHITE C3535 ASW	60	0,45	110x76	STAR WHITE	8	STAR WHITE	18x30	●	●	●	●	●	●	●
	CARBON C3535 ASC				CARBON		CARBON								
	TITANIUM C3535 AST				TITANIUM		TITANIUM								
3,0x4,0	STARWHITE C3040 ASW	60	0,45	110x76	STAR WHITE	8	STAR WHITE	18x30	●	●	●	●	●	●	●
	CARBON C3040 ASC				CARBON		CARBON								
	TITANIUM C3040 AST				TITANIUM		TITANIUM								

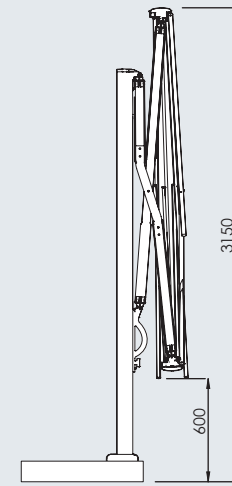
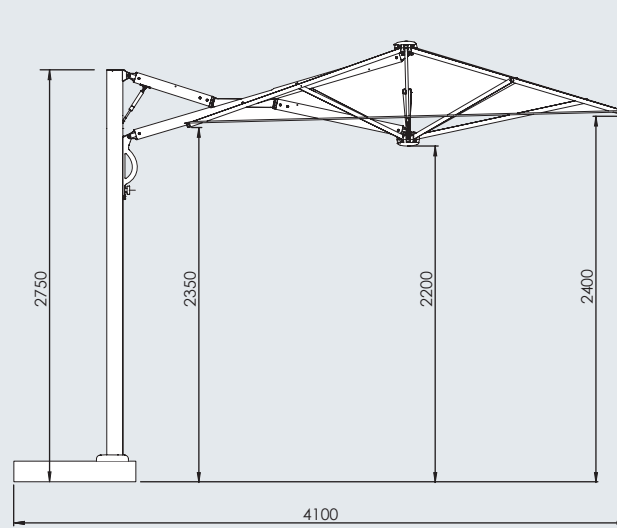
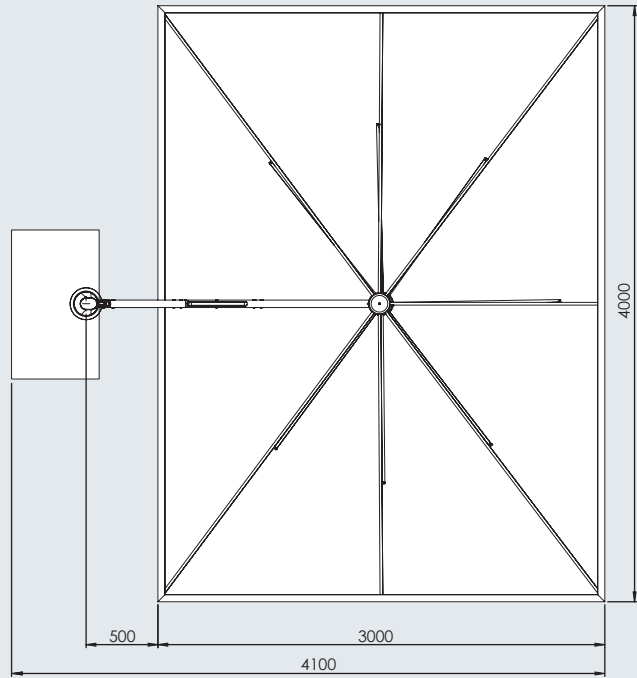

A1	T2	T3	T6	T7	T8	T9	S1
A1N	T2N	T3N	T6N	T7N	T8N	T9N	S1N
A1N	T2N	T3N	T6N	T7N	T8N	T9N	S1N
A1N	T2N	T3N	T6N	T7N	T8N	T9N	S1N

OPTIONAL

N°4 BC5151 N°12 BC5050	N°2 BV5050	FISSAGGIO TERRA INGROUND FIX
•	•	•
•	•	•
•	•	•